

Approval Sheet

| | | |
|---------------------------------------|------------------|----------------|
| (Product type):SMD | | |
| (Product name): 0603 Yellow-Green | | |
| (Part No.): | | |
| (Sample No.): | | |
| (Acknowledgement Numbers):20151023007 | | |
| (Signatures) | | |
| (Approved) | (Checked) | (Drawn) |
| | | |

| | | |
|--------------------------------|--|--|
| (Customer) | | |
| (Corporation): | | |
| (Material No.): | | |
| (Part No.): | | |
| (Customer Signatures) | | |
| | | |
| | | |

Feature

- *Low power consumption
- *Long life-solid state reliability
- *Available on tape and reel
- *RoHS compliant

Package outline dimensions

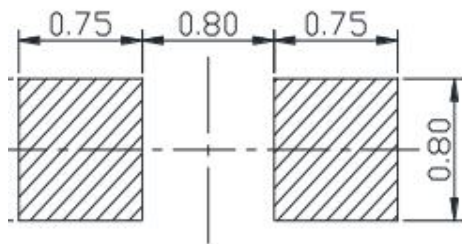
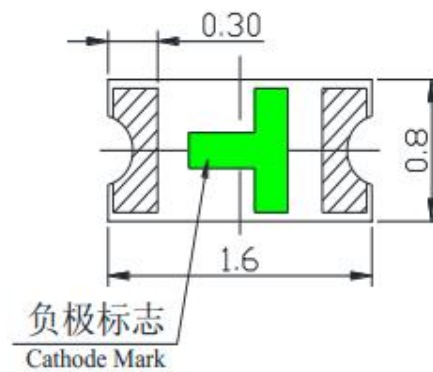
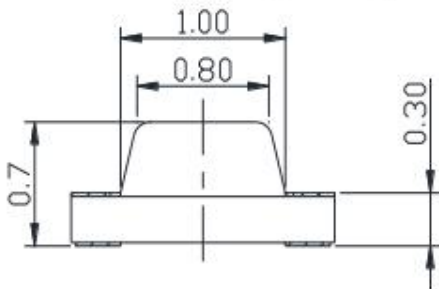
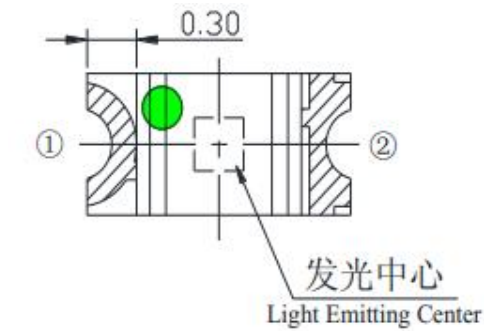

Recommended Soldering Pad

| | |
|---|--|
| 敷铜区域: | |
| Cuprum Area: | |
| 阻焊丝印区域: | |
| Solder Resist: | |
| *无特别规定时,公差:X.X±0.1mm, X.XX±0.05mm单位为mm* | |
| * The Tolerances Unless Mentioned is: X.X±0.1mm, X.XX±0.05mm, Unit= mm* | |

Note:

1. All dimensions are in millimeters (mm);
2. X.X is +/-0.1mm, X.XX is +/- 0.05mm unless otherwise noted;
3. The device has a single mounting surface. The device must be mounted according to the specifications.

Electrical characteristics data sheet

Selection Guide

| Part No. | Emitted Color | Resin color | Viewing Angle 20 _{1/2} |
|----------|---------------|-------------|------------------------------------|
| | Yellow- Green | Water Clear | 120 ° |

Absolute Maximum Ratings at Ta=25°C

| Parameter | Symbol | Value | Unit |
|---|--------|--------------|------|
| Power dissipation | Pd | 65 | mW |
| DC Forward Current | If | 20 | mA |
| Peak Forward Current ⁽¹⁾ | Ifp | 50 | mA |
| Reverse Voltage | Vr | 5 | V |
| Electro-Static-Discharge ⁽²⁾ (HBM) | ESD | 2000 | V |
| Operating Temperature | Topr | -30to+85 | °C |
| Storage Temperature | Tstg | -40to+100 | °C |
| Lead Solder Temperature | Tsol | 250 for 5sec | °C |

Notes:

- 1/10 duty cycle, 0.1ms pulse width
2. The products are sensitive to static electricity and must be carefully taken when handling products.

Electrical/Optical Characteristics Ta=25°C

| Parameter | Symbol | Condition | Value | | | Unit |
|------------------------------|--------|-----------|-------|------|------|------|
| | | | Min. | Typ. | Max. | |
| Forward voltage | Vf | If=20mA | 1.6 | 2.0 | 2.6 | V |
| Luminous intensity | Iv | If=20mA | 20 | 36 | --- | mcd |
| Dominant wavelength | λd | If=20mA | 565 | 570 | 575 | nm |
| peak wavelength | λp | If=20mA | -- | 575 | -- | nm |
| Spectrum Radiation Bandwidth | Δ λ | If=20mA | -- | --- | 24 | nm |
| Reverse current | Ir | Vr=5V | --- | --- | 10 | μA |

Notes:

1. Forward voltage: ±0.1V
2. Wavelength: ±1.5nm
3. Radiant intensity: ±10%

Typical Electro-Optical Characteristics Curves

FORWARD CURRENT VS. FORWARD VOLTAGE

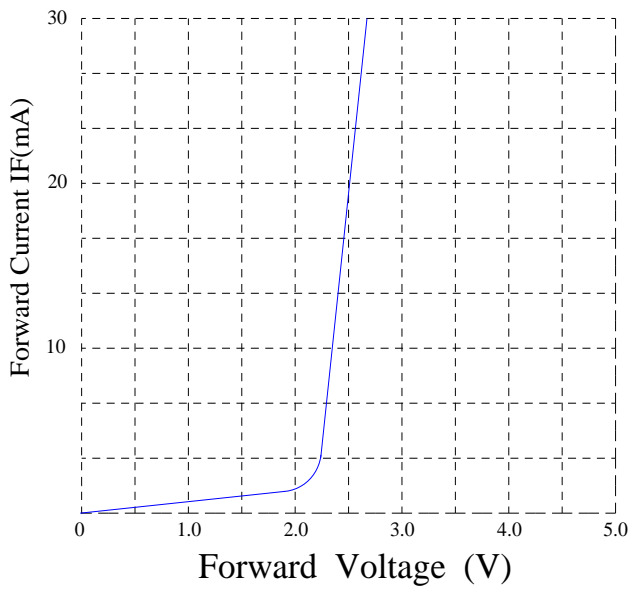

FORWARD CURRENT VS. LUMINOUS INTENSITY

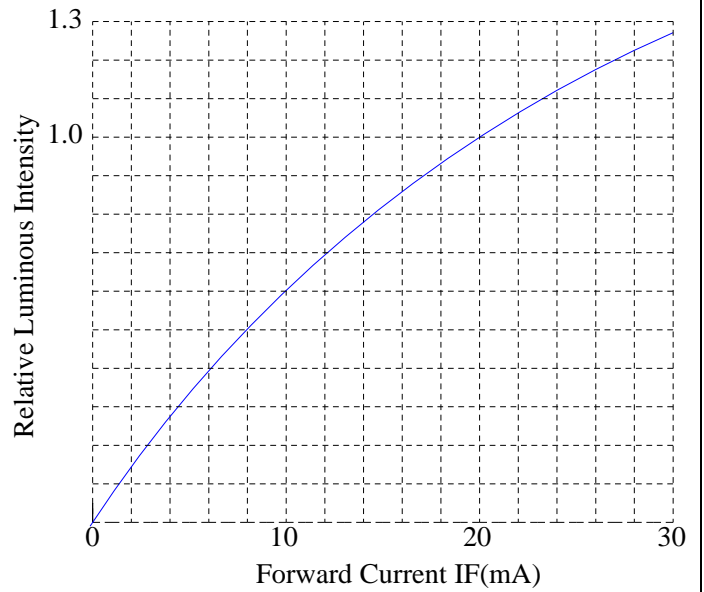

AMBIENT TEMPERATURE VS. FORWARD CURRENT

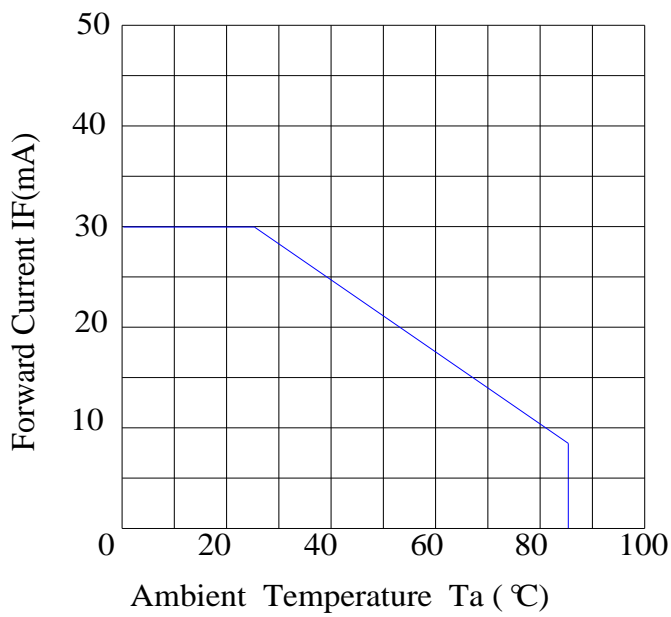

RADIATION DIAGRAM

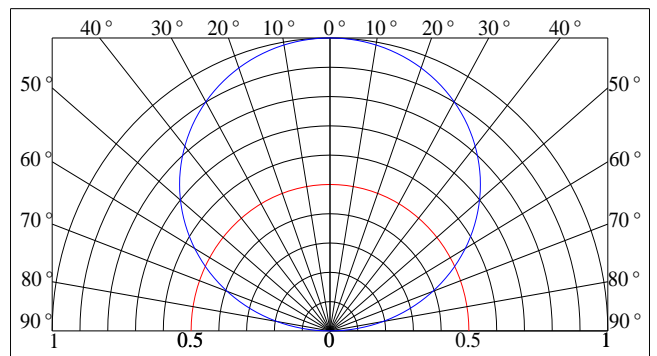

Bin Range of Technical Data Sheet

| Voltage code (IF=20mA, Ta=25°C) | | | Luminous code (IF=20mA, Ta=25°C) | | |
|------------------------------------|---------------------|------------|-------------------------------------|--------------------------|-----------|
| Bin Code | Forward voltage (V) | | Bin Code | Luminous Intensity (mcd) | |
| | min | max | | min | max |
| D | 1.6 | 1.8 | 1 | 20 | 30 |
| E | 1.8 | 2.0 | 2 | 30 | 45 |
| F | 2.0 | 2.2 | 3 | 45 | 70 |
| G | 2.2 | 2.4 | 4 | 70 | 90 |
| H | 2.4 | 2.6 | | | |

Color Bin Limits

| Color code (IF=20mA, Ta=25°C) | | |
|----------------------------------|--------------------------|------------|
| Bin Code | Dominant wavelength (nm) | |
| | min | max |
| H8 | 565 | 567 |
| H9 | 567 | 569 |
| H10 | 569 | 571 |
| H11 | 571 | 573 |
| H12 | 573 | 575 |
| | | |
| | | |
| | | |

Reliability Test Items and Conditions

1、 Test items and result

| Test Item | Ref. Standard | Test Condition | Note | Number of Damaged |
|------------------------------|---------------|---|-----------|-------------------|
| Resistance to Soldering Heat | JESD22-B106 | Tsld=260°C,10sec | 2 times | 0/100 |
| Temperature Cycle | JESD22-A104 | -40°C 30min ↓↑ 5min 100°C 30min | 100 cycle | 0/100 |
| Thermal Shock | JESD22-A106 | -40°C 15min ↑↓ 100°C 15min | 100 cycle | 0/100 |
| Power temperature Cycling | JESD22-A105 | On 5min -40°C>15min ↑↓↑↓<15min Off 5min 100°C>15min | 100 cycle | 0/100 |
| High temperature Storage | JESD22-A103 | Ta=100°C | 1000 hrs | 0/100 |
| Low temperature Storage | JESD22-A119 | Ta=-40°C | 1000 hrs | 0/100 |
| Lift Test | JESD22-A108 | Ta=25°C IF=20mA | 1000 hrs | 0/20 |
| High Humidity Heat Lift Test | JESD22-A101 | 60°C RH=90 % IF=20mA | 1000 hrs | 0/20 |

2、 Criteria for judging damage

| Item | Symbol | Test Conditions | Criteria for Judgment | |
|--------------------|--------|-----------------|-----------------------|-------------|
| | | | Min | Max |
| Forward voltage | VF | IF=20mA | -- | U.S.L*)×1.1 |
| Reverse current | IR | VR=5V | -- | U.S.L*)×2.0 |
| Luminous intensity | IV | IF=20mA | L.S.L**)×0.7 | -- |

Notes:

U.S.L.: Upper Standard Level

L.S.L.: Lower Standard Level

Packaging Dimensions Specification

1、Carrier tape dimensions

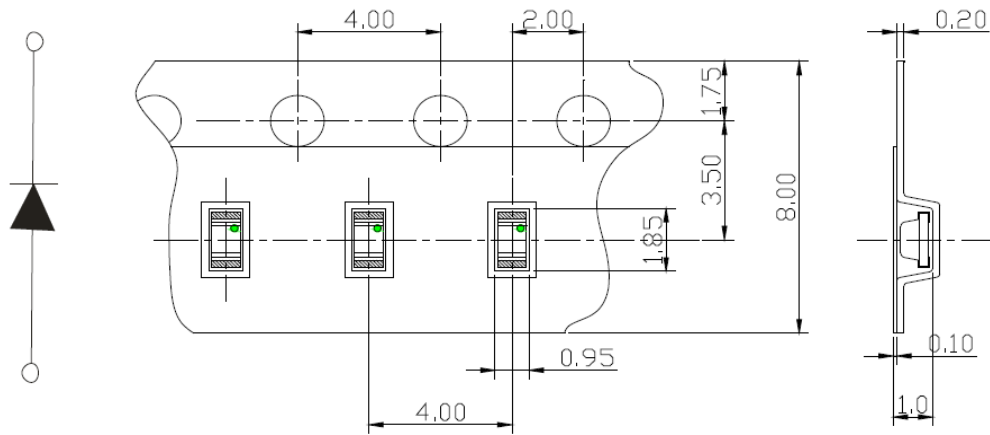

Notes:

- 1) All dimensions are in millimeters
- 2) Tolerance is ± 0.15 unless otherwise noted

2、Details of carrier tape

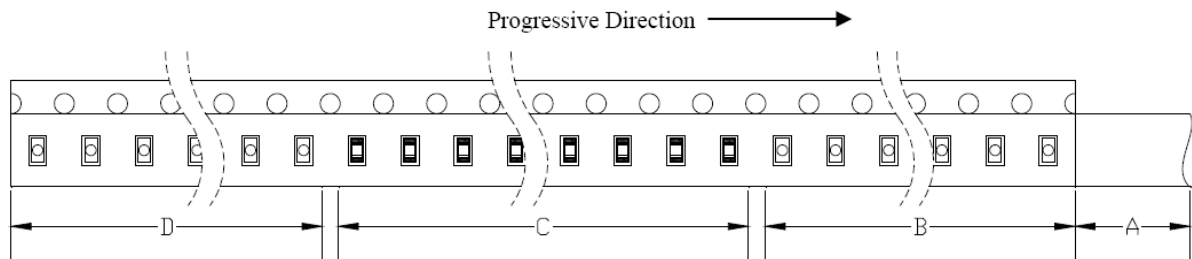

A: 盖带, 300 mm; B: 引导, 空带, 200mm; C: 编载产品 4000 只; D: 尾部, 空带, 200mm
 A: Top Cover Tape, 300mm; B: Leader, Empty, 200mm; C: 4000 Lamps Loaded; D: Trailer, Empty, 200mm.

3、Reel dimensions

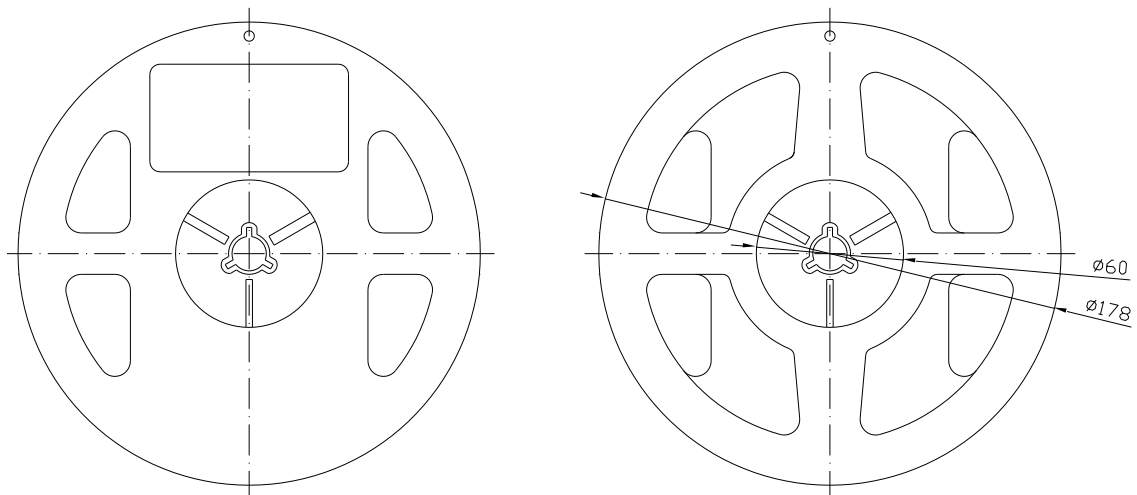

Packaging Dimensions Specification

4. Moisture-Proof and anti-static electricity

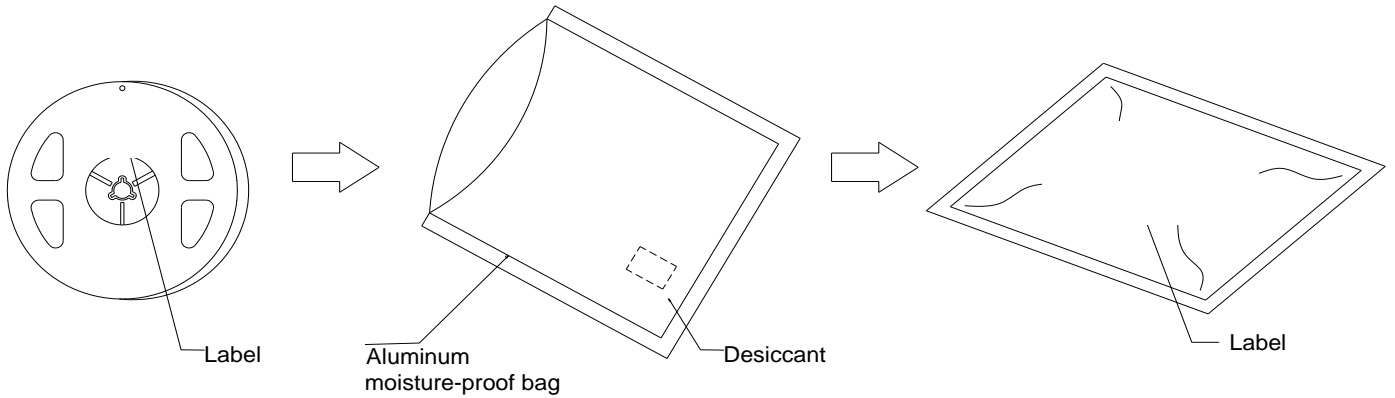

5. Label

| | |
|----------------|-------------|
| | RoHS |
| Part No. : | |
| VF :***** | |
| WD :***** | |
| IV :***** | |
| Q' TY :***** | |
| Lot No. :***** | |

Label Explanation:

| | |
|----------|--|
| VF | : Forward voltage |
| WD | : Dominant wavelength |
| IV | : Luminous intensity |
| VF\WD\IV | used to represent the corresponding Bin code |

Precautions

1、 Requirements for application and reflow soldering

Use the recommended curve in the under figure of Pb-free reflow soldering.

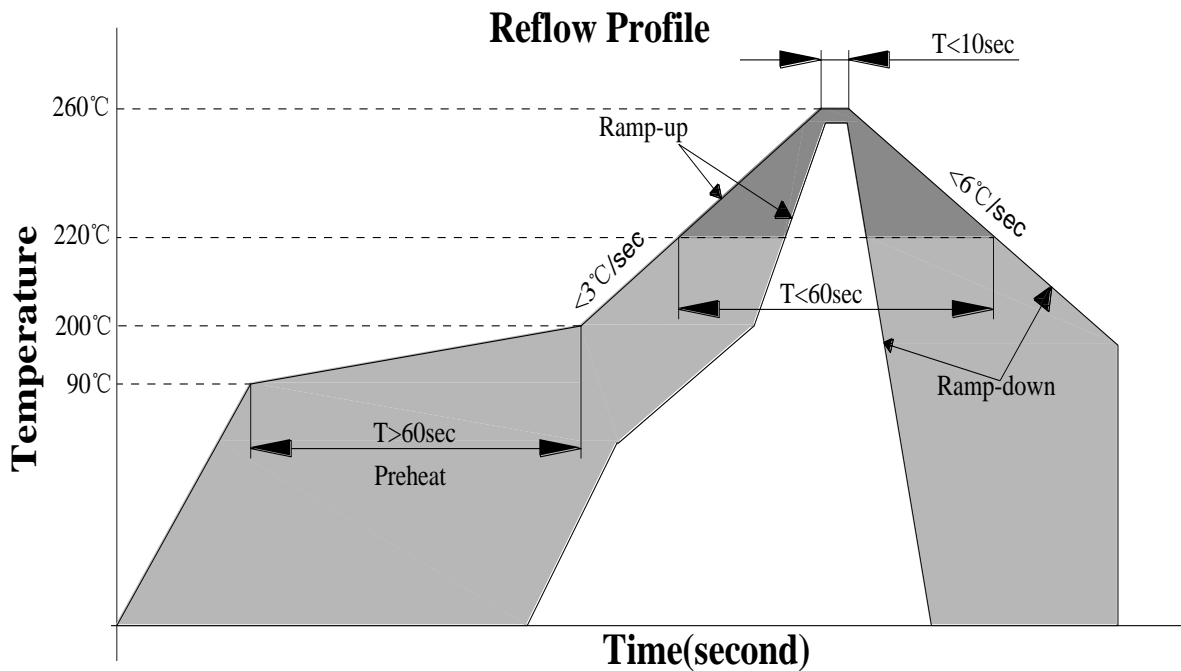

☆Notes for reflow soldering:

- 1) No more than twice for reflow soldering.
- 2) To ensure the quality of our LEDs, please do not put pressure on the lens of LEDs.
- 3) Please choose the right nozzle to avoid the damage to products due to the pressure.
- 4) Please put on the antistatic hand loop during the use. The worktable should be with antistatic finish. The equipments must be contacted with ground

☆Handwork soldering

- 1) During the soldering, the electronic soldering iron must be kept under the temperature of 350°C and the soldering time must not be beyond 3 seconds. No touch between the electronic soldering iron and colloid.
- 2) Handwork soldering is only allowed once. We won't take responsibility for more than that.
- 3) Avoid using sharp objects to compress products Colloidal Part directly.
- 4) Please put on the antistatic hand loop during the use. The worktable should be with antistatic finish. The equipments must be contacted with ground.

2、 Storage

☆Moisture proof and anti-electrostatic package with moisture absorbent material is used to keep moisture to a minimum.

Before opening the package, the product should be kept at 30°C or less and humidity less than 60%RH ,and be used in six months.

☆After opening the package, the product should be stored at 30°C or less and humidity less than 10%RH, and be soldered within 24 hours. It is recommended that the product be operated at the workshop condition of 30°C or less and humidity less than 60%RH.

☆If the moisture absorbent material has faded away or the LEDs have exceeded the storage time, baking treatment should be performed based on the following condition (75±5) °C for 24 hours.

3、 Static electricity

☆Static electricity or surge voltage damages the LEDs. Damaged LEDs will show some unusual characteristics such as the forward voltage coming lower, or the LEDs do not light at the low current, even not light.

All devices, equipment and machinery must be properly grounded. At the same time, it is recommended that wrist bands or anti-electrostatic gloves, anti-electrostatic containers be used when dealing with the LEDs.

4、 Vulcanization

☆LED curing is due to sulfur being in bracket and the +1 price of silver in the chemical reaction generated Ag₂S in the process. It will lead to the capacity of reflecting of silver layer reducing, light color temperature drift and serious decline, seriously affecting the performance of the product. So we should take corresponding measures to avoid vulcanization, such as to avoid using sulphur volatile substances and keeping away from high sulphur content of the material.

5、 Safety advice for human eyes

☆Viewing direct to the light emitting center of the LEDs, especially those of great luminous intensity will cause great hazard to human eyes. Please be careful.

6、 Design consideration

☆In designing a circuit about LED, the current through each LED must not exceed the absolute maximum rating specified for each LED. In the meanwhile, resistors for protection should be applied, otherwise slight voltage shift will cause big current change, burn out may happen.