

JYC LiFePO4 lithium batteries are able to provide you superior performance, durable life cycle, high safety and long lasting reliability under different situations. JYC insists on using state-of-art of high quality lithium cell and advanced BMS technology, our batteries are robustly designed for wide range applications. JYC's 12V, 24V, 48V/51.2V series lithium battery, which are popularly used in industrial, residential, commercial and military fields, such as solar/wind energy storage power system, home ESS, telecommunication site, UPS/Data Center backup power, electric vehicle, golf cart, floor machines, forklifts, robotics, marine, RV, medical equipment etc.

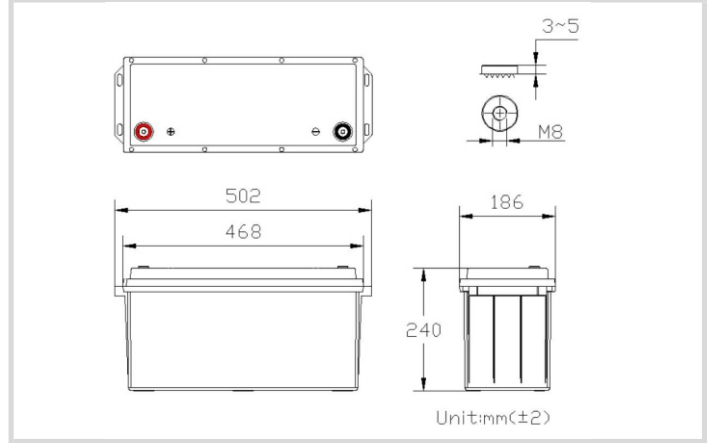

BATTERY SPECIFICATIONS

Nominal Voltage	12.8V
Nominal Capacity	200Ah@0.5C
Min. Capacity	198Ah@0.5C
Nominal Energy	2560Wh
Internal Resistance	≤ 6mΩ
Cycle Life	3500 Cycles @100A Charging/Discharging ,Until 80% Capacity
Self Discharge	≤ 2% per month at 25°C&50%SOC
Bluetooth&Heat	Optional

Standard Charging &Discharge

Charging Voltage	14.0~14.4V
Charging Mode	CC-CV
Recommended Charging Current	≤ 100A
Max.Charging Current	200A Continuous charging with this current may trigger BMS temperature protection.
Recommended Discharging Current	100A
Max. Continuous Discharging Current	200A
Max.Pulse Current	500(<10S)
Discharging Cut-off Voltage	10.8

Operating Condition

Charge Temperature	0°C to 45°C(32°F to 113°F) @60±25% Relative Humidity
Discharge Temperature	-20°C to 60°C(-4°F to 140°F) @60±25% Relative Humidity
Storage Temperature	0°C to 45°C(32°F to 113°F) @60±25% Relative Humidity

Structure

Casing	Plastic
Dimension(L*W*H*TH)	502*186*240mm
Weight	Approx. 18.4Kgs
Terminal	M8
Water Dust Resistance	IP65

Number of batteries used in series and parallel

Maximum number of series connections	4PCS
Maximum number of parallel connections	4PCS

Certifications

- UL(Cell)
- CE(Cell/Battery)
- IEC62133(Cell)
- UN38.3(Cell/Battery)
- ROHS(Cell)
- IEC62619(Cell)

Constant Current Discharge Data (Amperes @ 25°)

Discharge Time	1h	2h	3h	4h	5h	10h	20h
Cut off voltage (10.8V)	200A	100A	66.7A	50A	40A	20A	10A

Constant Power Discharge Data (Watts @ 25°)

Discharge Time	1h	2h	3h	4h	5h	10h	20h
Cut off voltage (10.8V)	2414W	1254W	843W	636W	510W	258W	129W

Market Application



Low-speed car



Golf cart



Light EV



Robotics



Cleaning



Solar & Wind



Lighting

Battery characteristic curve

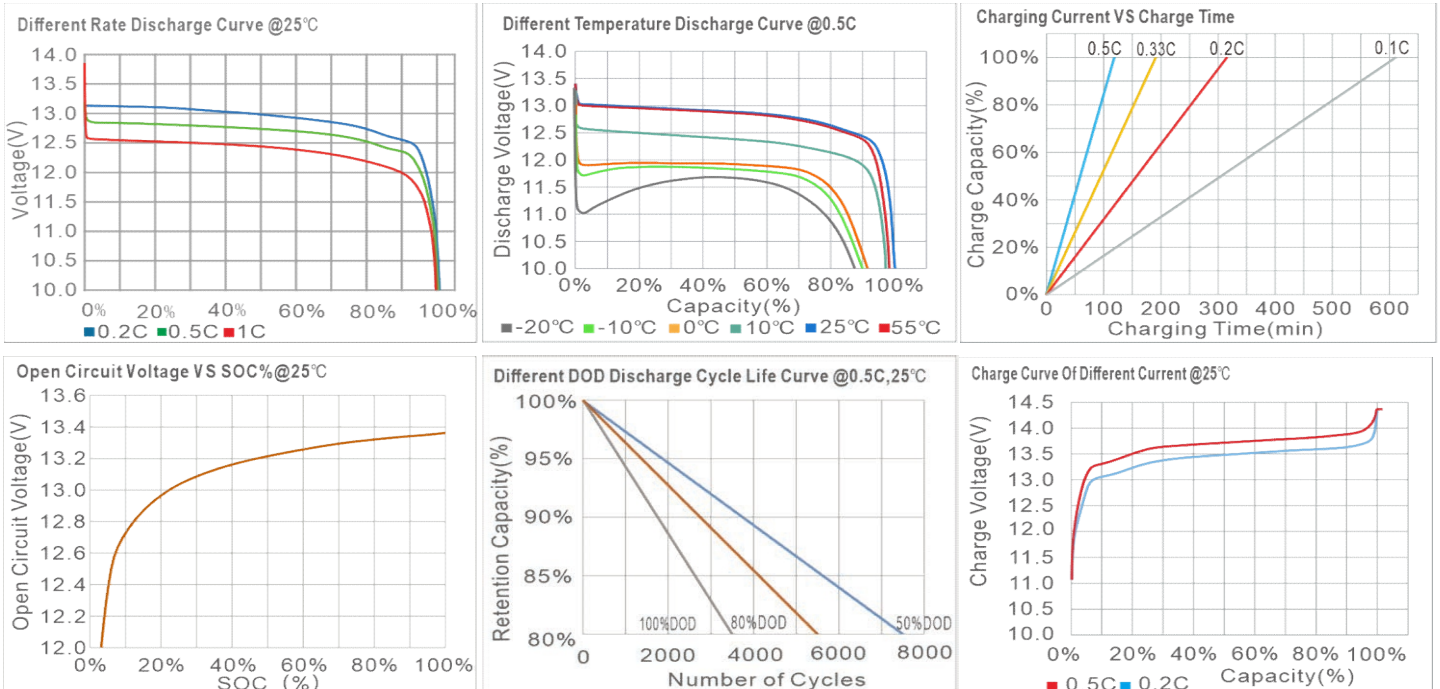

Note 1: Please always refer to the latest edition of our technical manual that published on our website to ensure safe and efficient operation.

Note 2: When make parallel connection, please full discharge batteries, then recharge after parallel connected; when series connect, please keep batteries with same remain capacity.

Note 3: Parallel connection is only for longer backup time, not for larger output power.